

J P Specialties, Inc. / Earth Shield® Waterstop 25811 Jefferson Avenue, Murrieta, CA 92562 951-763-7077 · www.jp-specialties.com		
TITLE <b>4.5" Corner Retrofit</b>		
PART NUMBER <b>JP540L</b>	DRAWN BY <b>DRP</b>	DATE <b>08/10</b>
CAD FILE NAME <b>JP540L Corner Retrofit</b>	APPROVALS	SIZE <b>A</b>

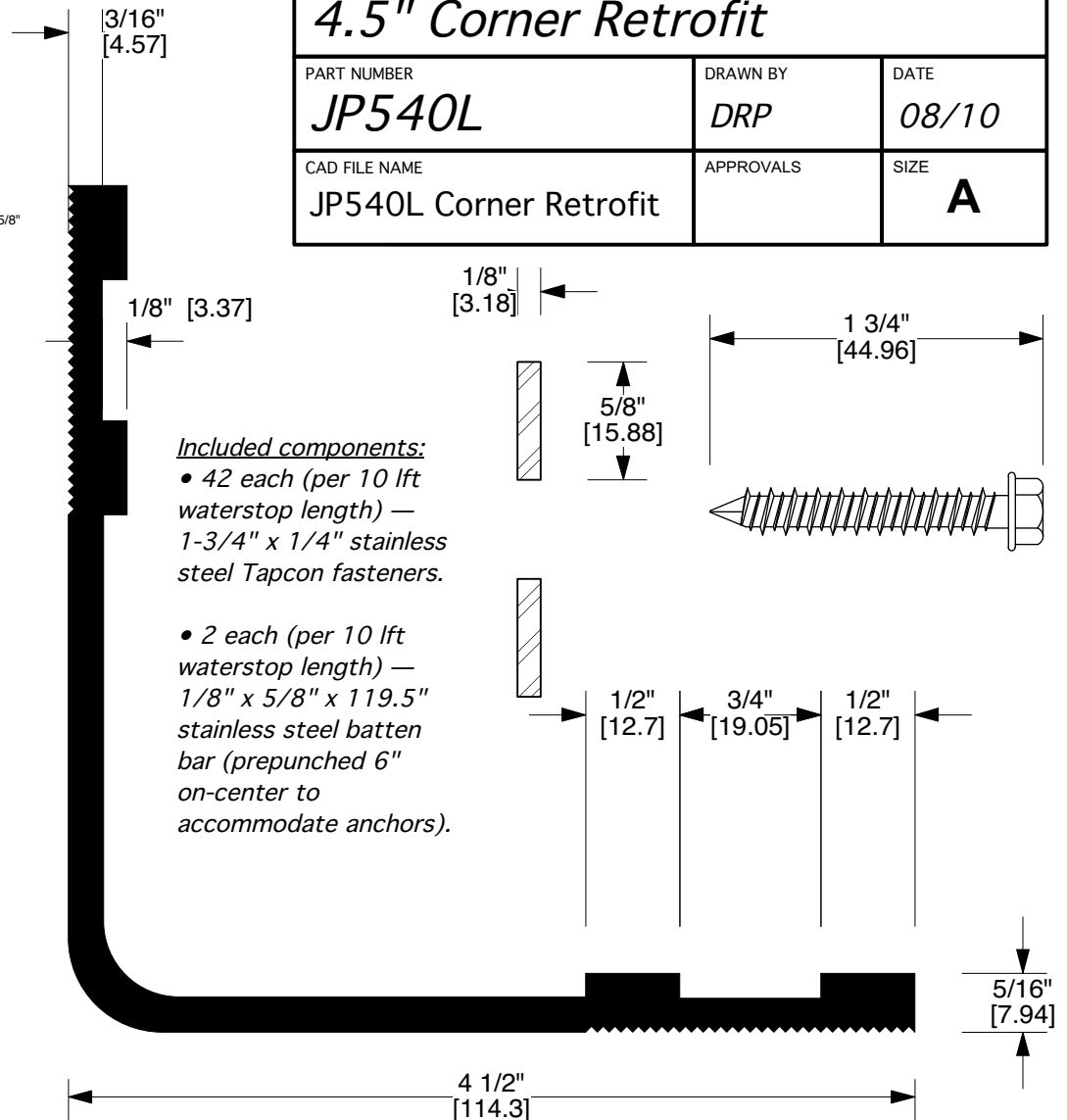

- Included components:**
- 42 each (per 10 lft waterstop length) — 1-3/4" x 1/4" stainless steel Tapcon fasteners.
  - 2 each (per 10 lft waterstop length) — 1/8" x 5/8" x 119.5" stainless steel batten bar (prepunched 6" on-center to accommodate anchors).

**Suggested Short Form Spec**

**Flexible Corner Retrofit Waterstop**

Waterstop indicated in drawings and specifications for sealing corner joints to be Earth Shield® Thermoplastic Vulcanizate (TPV) **Part No. JP540L** as manufactured by **J P Specialties, Inc.** - 25811 Jefferson Avenue, Murrieta, CA 92562 - Phone 800-821-3859; International 951-763-7077; Fax 951-763-7074; Web [www.earthshield.com](http://www.earthshield.com); E-mail [davidp@earthshield.com](mailto:davidp@earthshield.com)

1. Thermoplastic Vulcanizate (TPV) Waterstop shall be certified for ultra-violet (UV) exposure.
2. No equals or substitutions allowed.
3. Install per manufacturer's recommendations.