



# EARTH SHIELD®

## Metallic Waterstop for Extreme Chemical & Heat Resistance



All Earth Shield® Stainless Steel Waterstop profiles are available with factory fabricated change of directions, or Shop Made Fittings.

**W**aterstops play a critical role in the integrity of concrete structures. They provide a fluid-tight diaphragm when embedded in, and running through concrete joints. Earth Shield® Metallic Waterstop can stop even the most corrosive fluids in their tracks, even at severely elevated temperatures.

JP Specialties, Inc. is the leading manufacturer of chemical resistant waterstop and related concrete accessories. Our NSF 61 certified Earth Shield® line of chemical resistant waterstop is used throughout the world by major engineering firms and project owners for primary and secondary containment applications, as well as industrial wastewater treatment and ozone contactor structures. We invented and hold the patent on the technology used to mechanically weld thermoplastic waterstops.

Services offered include free blueprint take-off and shop drawings, on-site welding certification, and individual corrosion resistance certification for the project owner.

Earth Shield® Chemical Resistant Waterstop  
Phone: 800-821-3859; 951-763-7077  
Fax: 951-763-7074

[www.earthshield.com](http://www.earthshield.com)



## Earth Shield® Stainless Steel (SS)

### Waterstop Basic Use

Earth Shield® Stainless Steel Waterstop is used as a fluid-tight diaphragm, embedded in concrete, across and along the joint, for primary and secondary containment structures. Earth Shield® Stainless Steel Waterstop can stop even the most corrosive fluids in their tracks, even at severely elevated temperatures.

A variety of metals, grades, and gauges are available. Earth Shield® utilizes 20 gauge 316 low carbon as our standard alloy, which offers broad spectrum corrosion resistance to most aggressive media, and is virtually untouched by the deleterious effects of ozone, making it an ideal choice for ozone contactor structures used in modern water treatment plants.

Earth Shield® Stainless Steel Waterstop is available in many standard shapes and sizes including profiles for new construction and retrofit. All change of direction fabrications (shop made fittings) can be premanufactured leaving only straight butt welding for the Contractor in the field.

### Typical Applications

- Primary and secondary containment
- Refineries
- Ozone contactor structures
- Fuel storage (AST)
- LNG facilities
- Chemical plants

## Earth Shield® Advantages

- Outstanding fluid resistance to a wide range of aqueous-based fluids, oils, solvents, and hydrocarbons
- Extreme heat resistance (approx. 3,000°F)
- Extreme cold resistance, perfect for LNG
- Superior ozone and weathering

### Basic Use

Install Earth Shield® SS Waterstop in all concrete joints. Waterstop should be centered in, and run the extent of the joint. All changes of directions should be prefabricated (Shop Made Fittings), leaving only butt-welding for the field. ***If installing in an expansion joint, keep center "V" unembedded to allow it to accommodate movement as designed.***

Property	Test Method	Required Results
Tensile Strength	ASTM A240	90,000 psi
Elongation in 2" min.	ASTM A240	45%
Yield Strength	ASTM A240	45,000 psi
Rockwell B Hardness	ASTM A240	95
High Temperature Resistance		2,552°F

Splices in stainless steel waterstop shall be welded using a TIG (recommended) or MIG process utilizing a weld rod to match the stainless (weld rod: 316L; diameter — .035 to 045). Dam-



aged waterstops shall be repaired by removing the damaged portions and patching. Patches shall overlap a minimum of 1 inch onto undamaged portion of the waterstop. Weld all straight run material edge-to-edge (no overlapping).

### Preparation

1. Position waterstop to ensure proper distance from steel reinforcing bars to prevent rock pocket and honey comb.
2. Protect waterstop from damage during progress of work.
3. Clean waterstop after first pour to remove debris and dirt.

### Examination and Inspection

1. Prior to placement of concrete notify Engineer for field inspection approval.
2. Upon inspection of waterstop installation, replace any damaged or unacceptable waterstop and dispose of defective material.

### Installation

1. Position waterstop as indicated on drawings.
2. Center waterstop on joint, with approximately one-half of waterstop width to be embedded in concrete on each side of the joint.
3. Allow clearance between waterstop and reinforcing steel a minimum of one and a half times the largest aggregate size. (This prevents rock pockets and air voids caused by aggregate bridging.)
4. Carefully place concrete without displacing waterstop from proper position.
5. Thoroughly and systematically vibrate concrete in the vicinity of the joint and to maximize intimate contact between concrete and waterstop.
6. After first concrete pour, clean unembedded waterstop leg to ensure full contact of second concrete pour. Remove laitance, spillage, form oil and dirt.

### Technical Assistance

Qualified technical assistance is available during any phase of your construction project.

### Specifications

Standard 3-part Specifications are available at

our website in Microsoft® Word and Adobe® PDF format, and upon request in printed and a variety of computer word processor formats. Call our Technical Sales Staff for additional help with your specification.

### Suggested Proprietary Short Form Guide Specification Section 03150 (Master Format 2004 – 03 15 13)

Stainless Steel Chemical Resistant Waterstop Waterstop indicated in drawings and specifications for contraction (control), expansion and construction joints shall be Earth Shield® Stainless Steel Chemical Resistant Waterstop Part No. ##### [Designer insert appropriate part number here] as manufactured by JP Specialties, Inc.; Murrieta, CA 92562; Phone 951-763-7077; www.earthshield.com

1. *Stainless Steel (SS) Waterstop shall conform to EPA Title 40 CFR Section 265.193. The suitability of the waterstop for a specific application should be determined by specific testing for that particular requirement. Project-specific certification to be provided by the manufacturer.*
2. *No equals or substitutions allowed.*

### Shop Made Fittings

Intersection and change of direction stainless steel waterstops shall be shop fabricated as manufactured by JP Specialties, Inc.; Murrieta, CA 92562; Phone 951-763-7077; www.earthshield.com

1. *No equals or substitutions allowed.*

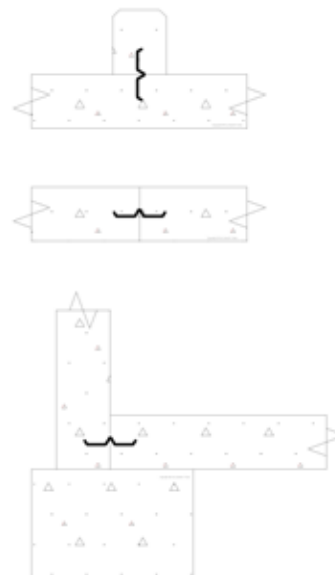

# Stainless Steel Waterstop and Standard Fabrications

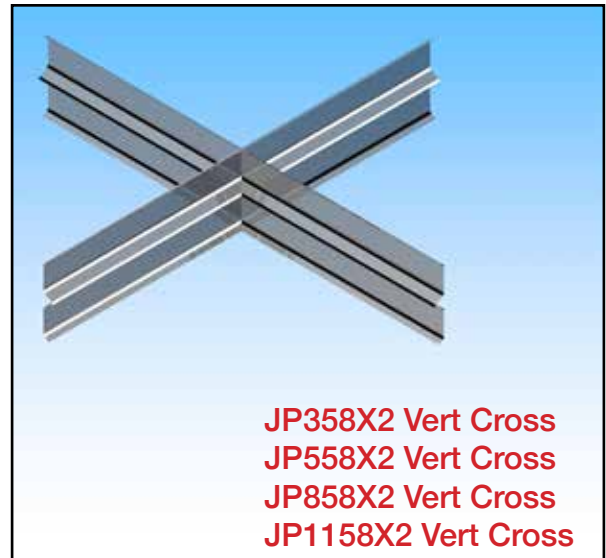
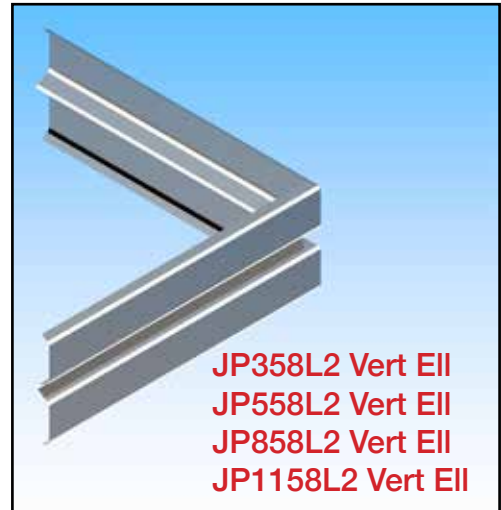
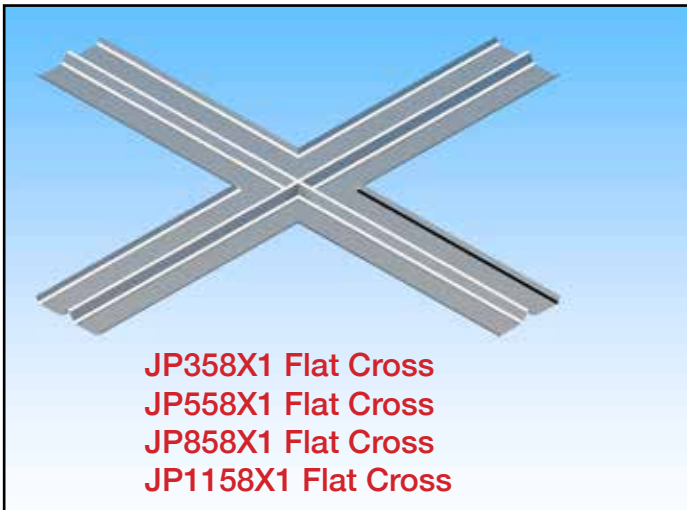
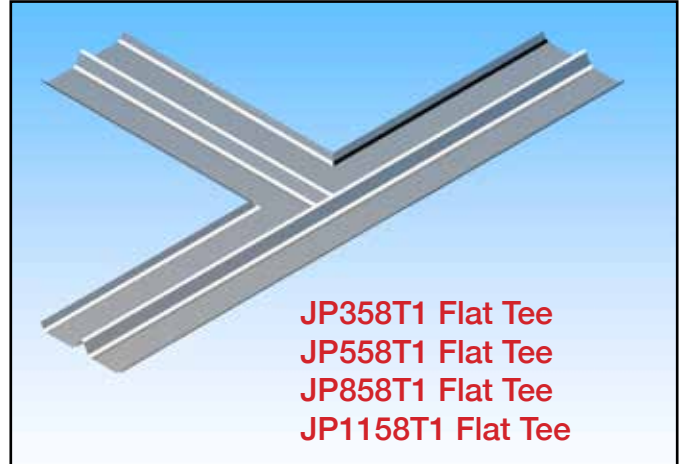
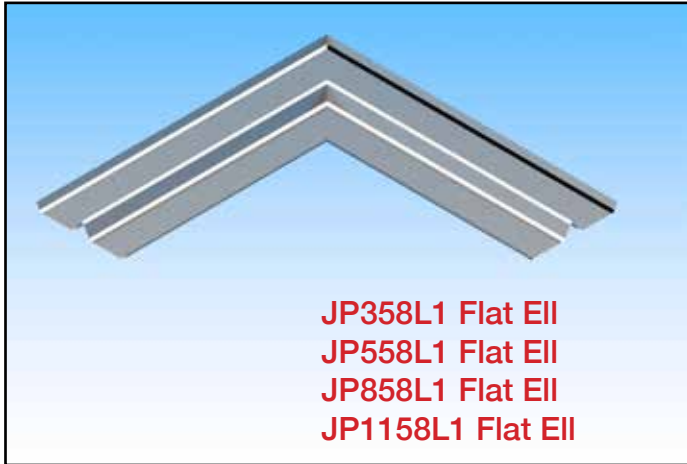

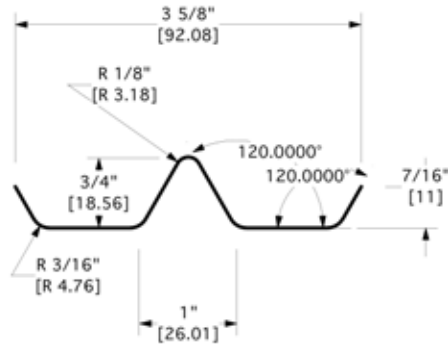

**JP358**  
**4" Stainless Steel Waterstop**  
 50 ft Head of H<sub>2</sub>O

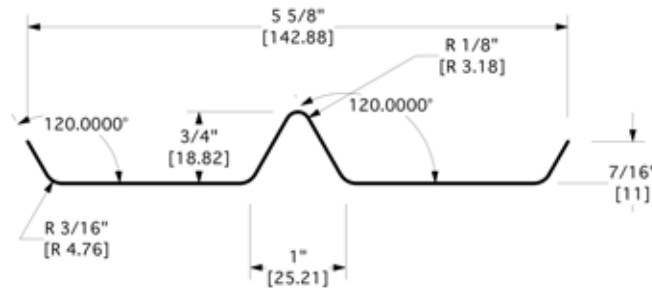

**JP558**  
**6" Stainless Steel Waterstop**  
 75 ft Head of H<sub>2</sub>O

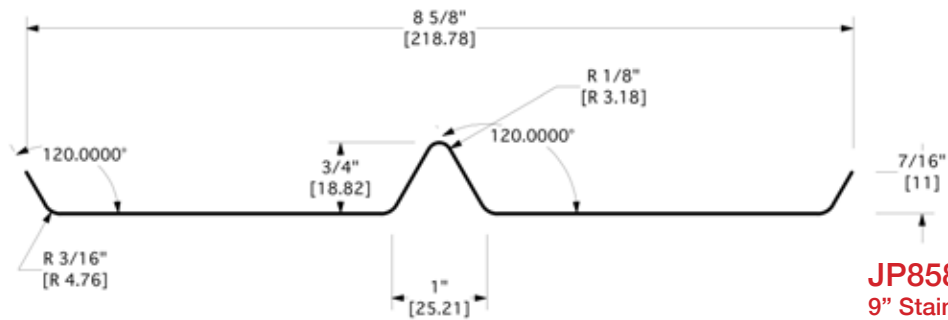

**JP858**  
**9" Stainless Steel Waterstop**  
 125 ft Head of H<sub>2</sub>O

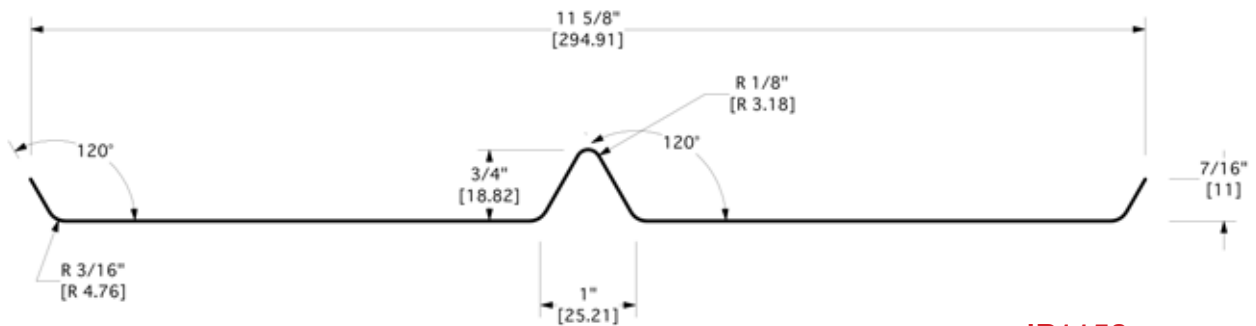

**JP1158**  
**12" Stainless Steel Waterstop**  
 175 ft Head of H<sub>2</sub>O

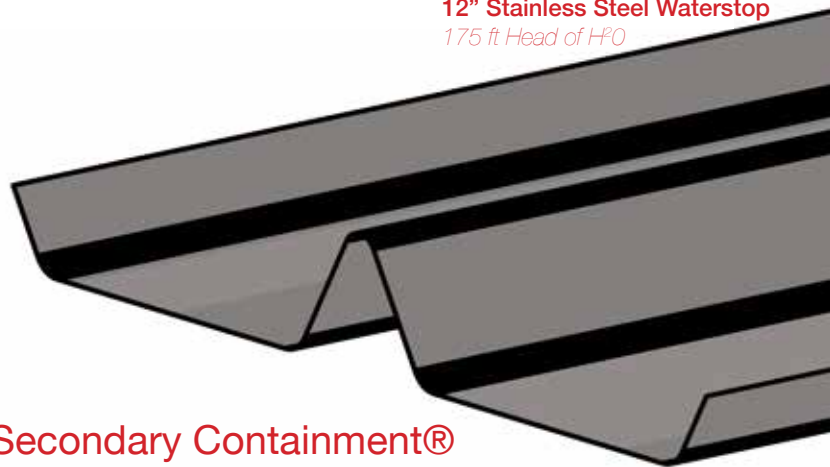

The Primary Choice for Secondary Containment®

# Retrofit Waterstop Systems

## for New to Existing Concrete Joints

**R**etrofit waterstop is designed to provide a fluid-tight seal between existing and new concrete construction, without resorting to the labor-intensive and structurally destructive saw-cut-and-grout method. It is ideal for constructing a new containment curb or wall to an existing slab, or joining a new slab to an existing wall. Special profile fabrications are available for columns and pipe penetrations.

All of our retrofit waterstops are sold as a system, and include all the necessary stainless steel bars and bolts. We also offer a high-quality chemical resistant novolac epoxy – VEN 1000. Earth Shield® retrofit waterstops are manufactured with grade 316L (low carbon) stainless steel, which provides for unsurpassed chemical resistance.

Like all our stainless steel waterstops, Earth Shield® retrofit can be heat-welded using a standard TIG (or MIG) welding method. This allows for

easy field fabrications, and allows the waterstop to function as a continuous, homogeneous, fluid-tight diaphragm. Waterstop change of directions can be purchased along with straight stock, and custom, fit-to-print waterstop modules are produced to order. Prefabricated ells, tees, tank pads, column fittings, and many others are in stock and ready to ship.

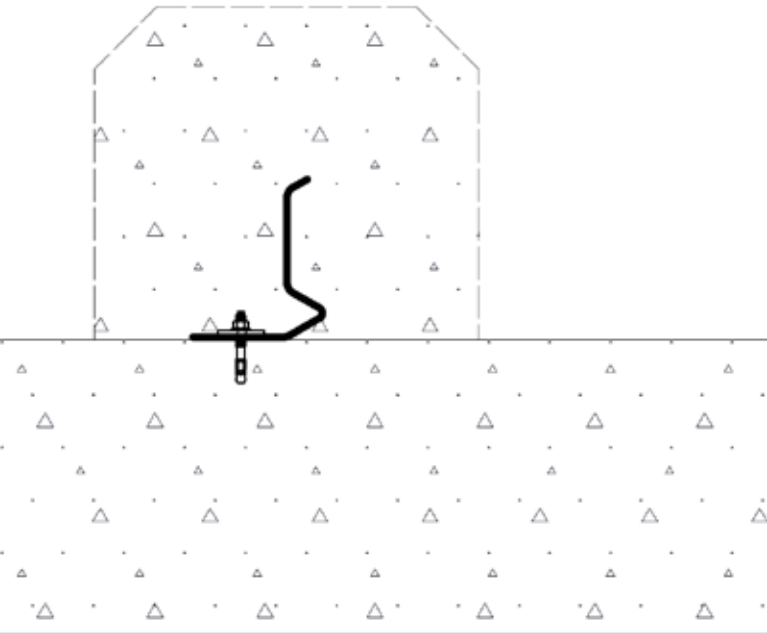

Containment Curb

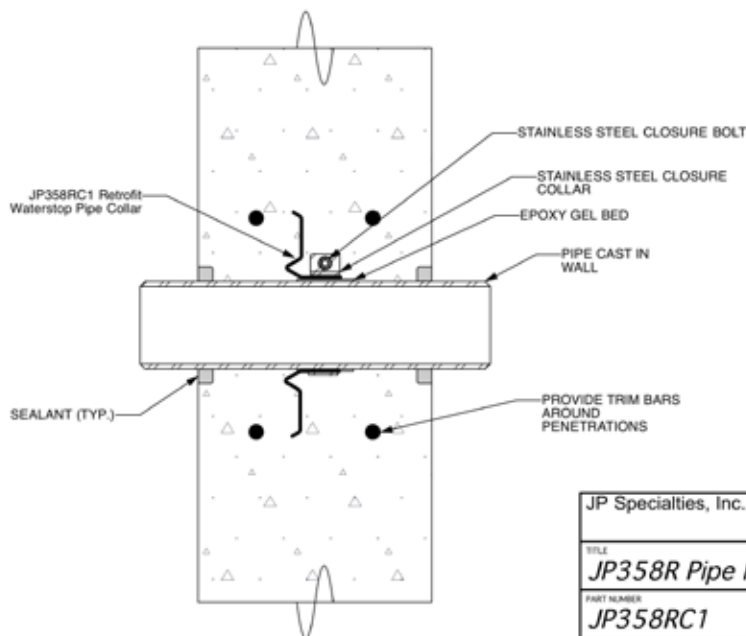

JP Specialties, Inc. / Earth Shield®		
TITLE <i>JP358R Pipe Fitting</i>		
PART NUMBER <i>JP358RC1</i>	DRAWN BY <i>DRP</i>	DATE <i>04/11</i>
CAD FILE NAME <i>JP358R Pipe Fitting</i>	APPROVALS	SIZE <b>A</b>

The Primary Choice for Secondary Containment®

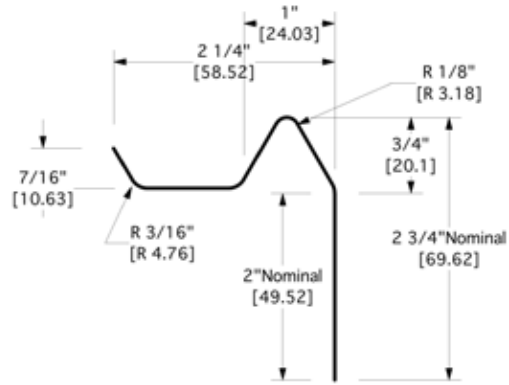

**JP358R**  
**4" Retrofit Waterstop System**  
*(Includes all anchors)*  
 50 ft Head of H<sub>2</sub>O

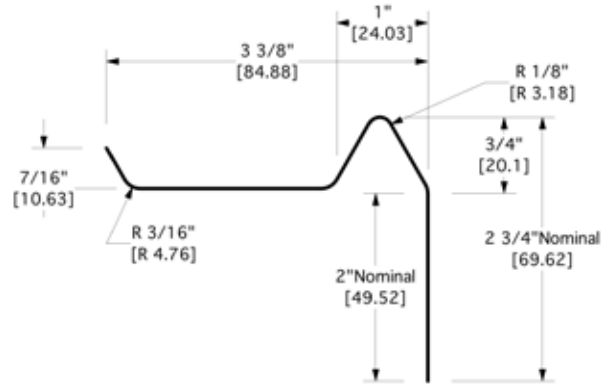

**JP558R**  
**6" Retrofit Waterstop System**  
*(Includes all anchors)*  
 75 ft Head of H<sub>2</sub>O

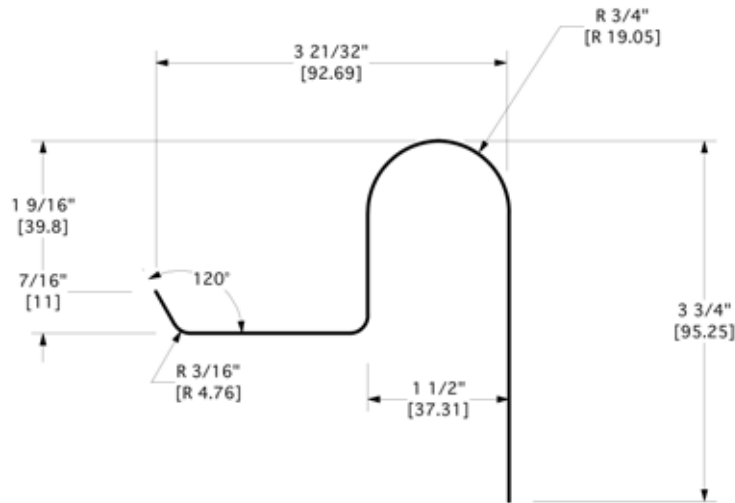

**JP578R**  
**Movement Retrofit Waterstop System**  
*(Includes all anchors)*  
 75 ft Head of H<sub>2</sub>O

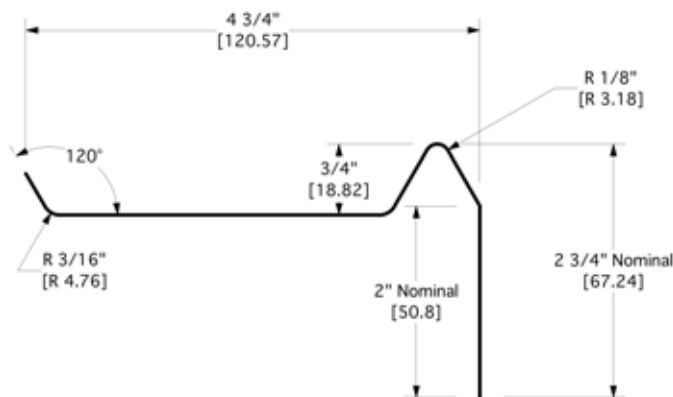

**JP858R**  
**8" Retrofit Waterstop System**  
*(Includes all anchors)*  
 125 ft Head of H<sub>2</sub>O

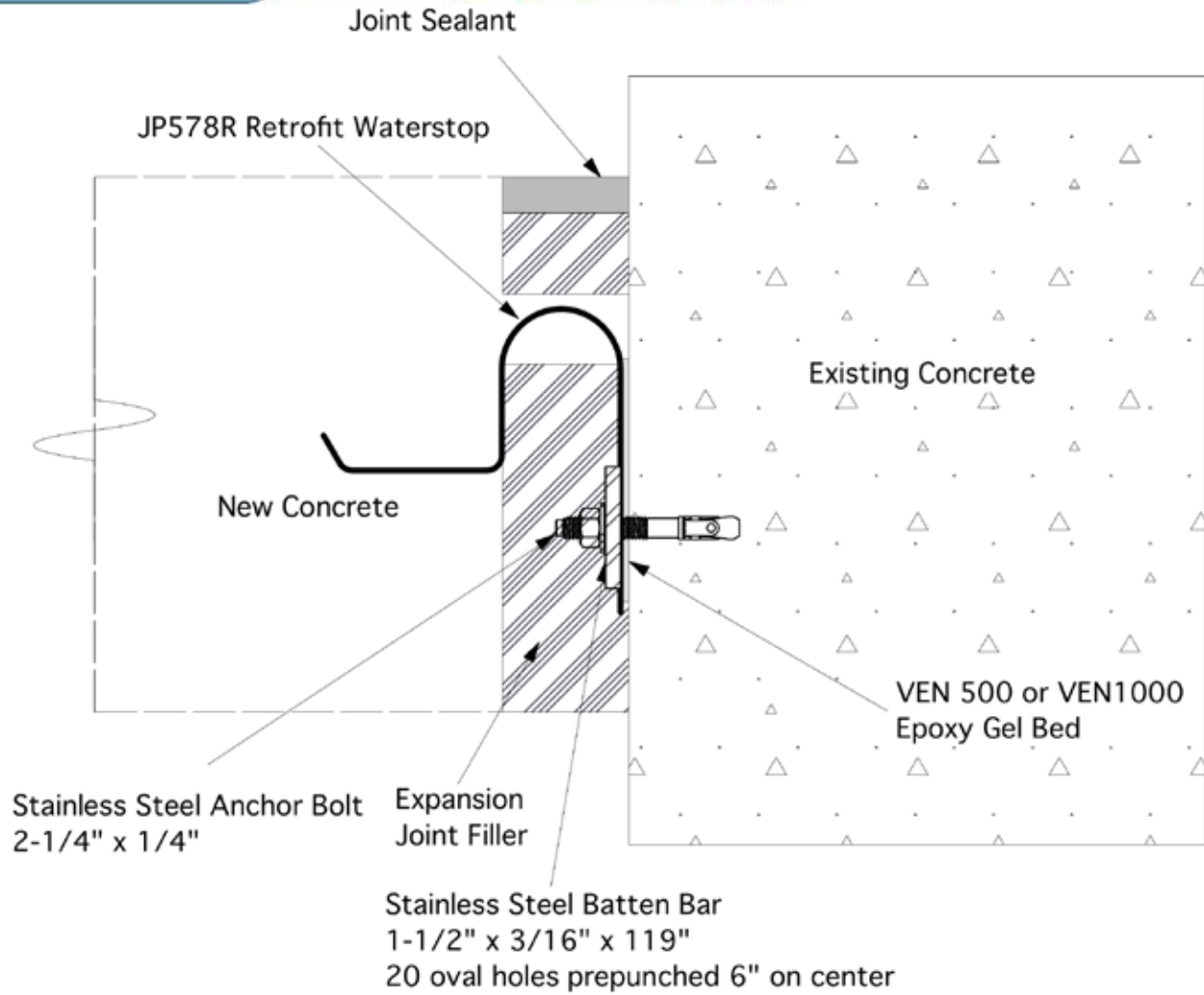

# Movement Joint Systems

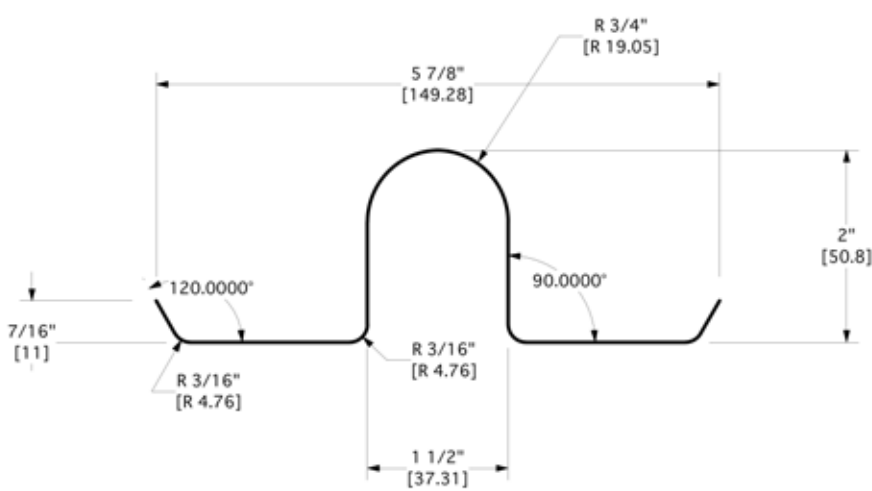

**JP578**  
**Movement Waterstop System**  
 75 ft Head of H<sub>2</sub>O

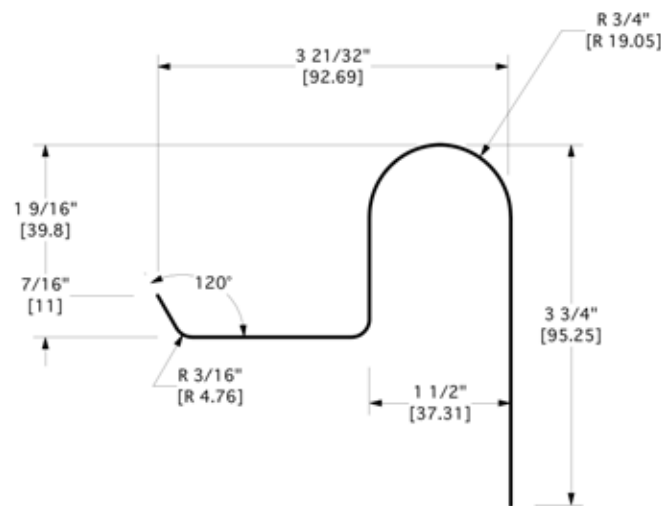

**JP578R**  
**Movement Retrofit Waterstop System**  
*(Includes all anchors)*  
 75 ft Head of H<sub>2</sub>O

The Primary Choice for Secondary Containment®



# Base Seal Waterstop Systems

## Easy to Install, Lay Flat on Subgrade

**B**ase seal (aka Rear Guard) waterstop is ideal for flat pavement jobs such as runways, large containment slabs, etc. Base seal waterstop is by far the easiest waterstop to install... Simply lay the waterstop directly on the compacted subgrade, place and finish concrete, and create control joint using saw cut or other method. The base seal provides a permanent, life-of-structure seal at the bottom of the joint. Base seal is suitable for construction, contraction (control), and expansion joints.

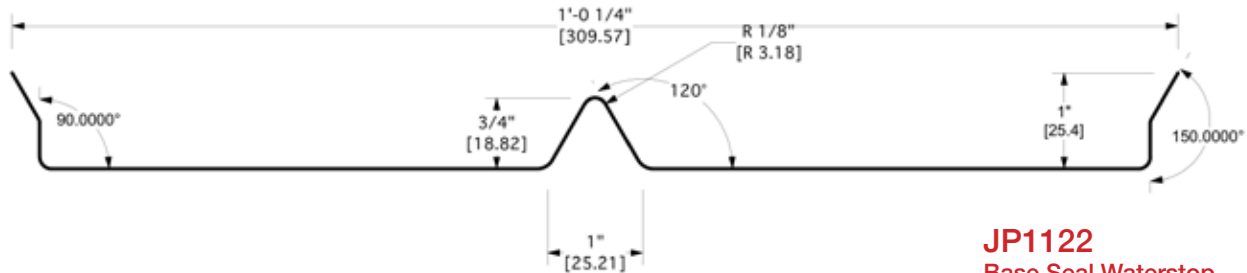

**JP1122**  
Base Seal Waterstop  
75 ft Head of H<sub>2</sub>O

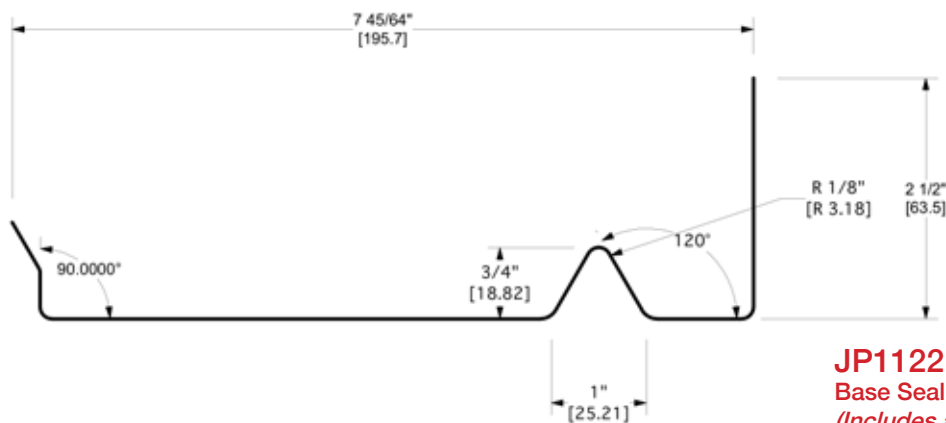

**JP1122R**  
Base Seal Retrofit Waterstop System  
(Includes all anchors)  
75 ft Head of H<sub>2</sub>O

*The Buncefield Incident (right). On December 11, 2005 a series of explosions rocked the Hertfordshire Oil Storage Terminal, located near Hemel Hempstead in Hertfordshire, England. The plastic waterstops that were in the fuel terminal joints all failed due to the high heat of the fire. The Health Protection Agency and the Major Incident Investigation Board provided advice to prevent incidents such as these from happening again, including the utilization of stainless steel waterstop in place at all concrete joints to prevent fuel from escaping the bund walls.*

*In July of 2014, JP Specialties, Inc. was contracted to provide our Earth Shield® Stainless Steel Waterstop (part nos. JP1122 and JP1122R) in the reconstruction and rehabilitation of the Hertfordshire Oil Storage Terminal.*



The Primary Choice for Secondary Containment®

# Made in t

## Waterstop for Che & Environments

Manufactured  
with pride by



J P SPECIALTIES, INC.

# www

# the U.S.A.

JP Specialties, Inc. manufactures a wide range of high-quality waterstop and waterstop accessories for the concrete construction industry. Our Earth Shield® line of chemical resistant waterstop is designed to offer solutions for today's unique regulatory compliance needs. Our waterstop welding equipment is used industry-wide as the standard for quality, high tensile strength waterstop welds. Knowing that a waterstop will only offer a fluid-tight barrier if change of directions are done properly, JP Specialties has been a leader since 1954 in Prefabricated Waterstop Modules and Shop Made Fittings.

## Chemical, Industrial, and Residential Applications

# WWW.EARTHSHIELD.COM

# Availability

## National and International Warehouses

Earth Shield® Stainless Steel Waterstop is readily available from a variety of sources:

- **Preferred Regional Stocking Partners** — *We are partners with some of the very best Concrete Accessories Distributors in the world. All our preferred partners have large stocking inventories and are factory trained to provide the utmost in on-site assistance.*
- **Distributor Sales** — *Earth Shield® can be special ordered from many distributor sales channels throughout the world.*
- **Factory Direct** — *Earth Shield® may be contacted directly for project quotation and product purchase (call 800-821-3859).*
- **Web Store** — *Earth Shield® products can be ordered directly on our web store at <http://waterstop.enstore.com>*

# Services

- **Project and Product Certification** — *We assist the Design Engineer and Project Owner with individual project and product certification. When you specify our waterstop, you can be assured it is the correct product for your application.*
- **Take-off Assistance** — *For the Contractor.*
- **Shop Drawings**— *3-D isometric and 2-D CAD details are available to assist the project.*
- **On-site waterstop welding certification class** — *\$500.00 flat fee*
- **On-site waterstop installation assistance** — *\$1,000.00 per day*
- **Telephone and Web-based assistance** — *Always FREE*

Distributed by:

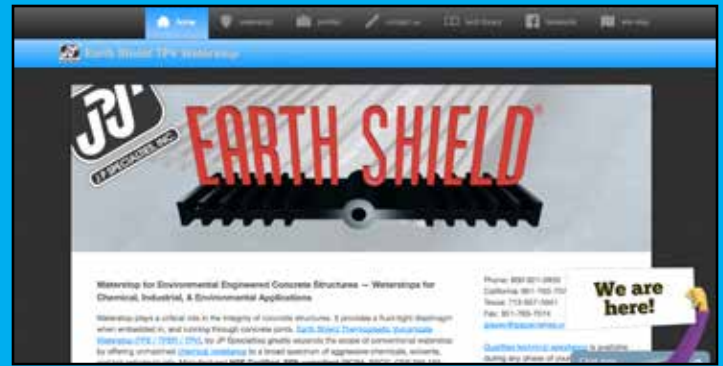

Visit Earth Shield® on the Web at [www.earthshield.com](http://www.earthshield.com)

## Earth Shield® Waterstop Limited Warranty

JP Specialties, Inc. warrants to the Buyer that this product is new and will be free from defects and will perform as represented in writing subject to the two (2) following conditions: First, the application of the product and the concrete construction practices used in the application are in accordance with JP Specialties, Inc. recommendations; and, Second, the Buyer has selected the proper product for the specific application required.

Any information supplied in good faith by JP Specialties, Inc. with respect to its products is believed to be correct. JP Specialties, Inc. Makes no representation or warranties, expressed or implied, as to the accuracy or completeness of such information.

The exclusive remedies of the Buyer and the limit of the liability of JP Specialties, Inc. from any and all losses or damages resulting from the use of this product shall be either full refund of the purchase price to the Buyer of this product or the replacement of the quantity of product purchased by the Buyer at the discretion of JP Specialties, Inc.

All supplied testing data has been performed by independent testing laboratories.

Earth Shield® Chemical Resistant Waterstop  
Phone: 800-821-3859; 951-763-7077  
Fax: 951-763-7074

[www.earthshield.com](http://www.earthshield.com)



[www.facebook.com/waterstop](https://www.facebook.com/waterstop)